

# Original Operating Instructions

## UV Compact Flame Detector IFC 50

Type: IFC 50  
Document: TB IFC 50 EN Rev.1



BST Solutions GmbH  
Eggerscheidter Strasse 57  
D-40883 Ratingen Germany  
Telephone +49 (2102) 10059-59  
· Facsimile +49 (2102) 10059-79  
<http://www.bst-solutions.de>

---

<b>1</b>	<b>General aspects</b>	<b>3</b>
1.1	Preamble	3
<b>2</b>	<b>Safety</b>	<b>3</b>
2.1	Intended use	3
2.1.1	Safety test	3
<b>3</b>	<b>Technical data</b>	<b>4</b>
3.1	General characteristic features	4
3.2	Electrical system, optical system, mechanical system	4
3.3	Weight	5
3.4	Dimensions	5
3.5	Block diagram IFC 50	5
<b>4</b>	<b>Transport, installation and connection</b>	<b>6</b>
4.1	Scope of delivery	6
4.2	Dimensions IFC 50	7
4.3	Installation	7
4.3.1	Alignment of IFC 50	8
4.3.2	Usage of glasses and lenses	8
4.3.3	Purge air connection	8
4.4	Connection	9
4.4.1	Electrical connection	9
4.4.2	Connection diagram IFC 50	9
4.4.3	Connection to BMS	10
4.5	Storage	10
<b>5</b>	<b>Description</b>	<b>11</b>
5.1	Functional description IFC 50	11
<b>6</b>	<b>Operation of the flame detector</b>	<b>12</b>
6.1	Test of the flame detector	12
6.2	Operating indicator LED	12
<b>7</b>	<b>Maintenance and servicing</b>	<b>13</b>
7.1	Cleaning	13
7.2	Maintenance interval	13
7.3	Safety check	13
7.4	Behavior in case of malfunction	13
<b>8</b>	<b>Troubleshooting</b>	<b>14</b>
<b>9</b>	<b>Order data</b>	<b>15</b>



**10**

**Accessories**

**16**

## **1 General aspects**

### **1.1 Preamble**

This Quick Guide provides an overview of the technical data of the IFC 50, its application, installation and handling, as well as ordering data and accessories.

---

Binding is solely the original operating instructions of the IFC 50 in its currently valid version.  
To reflect the original operating instructions of the IFC50:

BST Solutions GmbH

Eggerscheidter Str. 57

D-40883 Ratingen

Tel. +49 (0) 2102/10059-59

Fax +49 (0) 2102/10059-79

E-mail: [info@bst-solutions.de](mailto:info@bst-solutions.de)

Internet: [www.bst-solutions.de](http://www.bst-solutions.de)

## 2 Safety

### 2.1 Intended use

The IFC 50 is a compact UV flame detector, which has been developed for industrial firing systems. It provides a galvanically isolated normally open contact and a galvanically isolated normally closed contact both with high switching power. The IFC 50 is in accordance with UL 372-2, CSA C22.2 and EN 298 designed for burner management systems that check the existence of a flame signal after every shut down.

The design of the UV sensor ensures that the flame detector does not react to background radiation from hot refractory or from any other infra-red light source.

The internal increase of the UV tube voltage immediately after apply supply voltage ensures the safety requirements for the examination of the UV tube to through-ignition for intermittend operation.

By means of its diopter, which is at the same time the mechanical interface to the combustion chamber, the IFC can be easily adjusted to special requirements with its accessories.

Via the LED the flame intensity is visualized without effort. An easy diagnostic of the flame intensity is directly possible at the combustion chamber.

#### **▲WARNING**

*Danger when improperly used !*

*The device may cause hazards if it is not used as intended and/or for any other purposes.*

*The device has to be used only for the purposes for which it is intended.*

*The procedures described in the operating instructions have to be observed.*

The manufacturer/supplier shall not be liable for damage resulting from use for non-intended purposes. The user/operating company alone shall bear the risk.

#### 2.1.1 Safety test

#### **▲WARNING**

*In order to ensure correct operation, the compact flame detektor IFC 50 as well as flame amplifiers of all applications have to be tested several times by starting and stopping the burner several times. In all cases the flame relay has to be switched off reliably in case of an absent flame. Carry out this test whilst several neighbouring burners are started and stopped and different boiler outputs are used. This is an indispensable pre-requisite for a safe and correct operation of the device !*

### 3 Technical data

#### 3.1 General characteristic features

- UV-Tube
- Fully electronic construction
- Galvanically isolated normally closed and normally opened contact
- Intermittent operation
- CE 085CN0133

#### 3.2 Electrical system, optical system, mechanical system

Optical features	185 to 265 nm, tolerated flame signal fades approx. 200 ms
Orientation	axial
Lifetime of the tube	approx. 10000 h
Distance to flame	< 2 m
Input	230 V AC 120 V AC ( optional ) Nominal frequency 50-60 Hz
Prefuse	max. 1 A , slow
consumption	max. 18 mA
Operating temperature	-20 to +60°C (temperatures higher than 50°C reduces life of the UV tube )
Operating position	any position
Kind of protection	IP 65
Protection class	I, FELV
Humidity	max. 95% r.H., non-condensing
Electrical connenction	Amphenol eco mate plug C016
Restart time	>5s between controlled shut-down and renewed heat request

Output data	Flame on reaction time typically 0.5s Log off time <0.5s
Relay output ( 1 x normally closed contact, 1 x normally open contact)	Floating VDE 0110, class C max. switching current 1 A max. switching power 250 VA max. switching voltage 250 V AC

### 3.3 Weight

Weight approx. 0.650 kg

### 3.4 Dimensions

Length ( without plug or gland) 117.1 mm

Width 66 mm

Height 92 mm

Dimensions see under item 4.4

### 3.5 Block diagram IFC 50

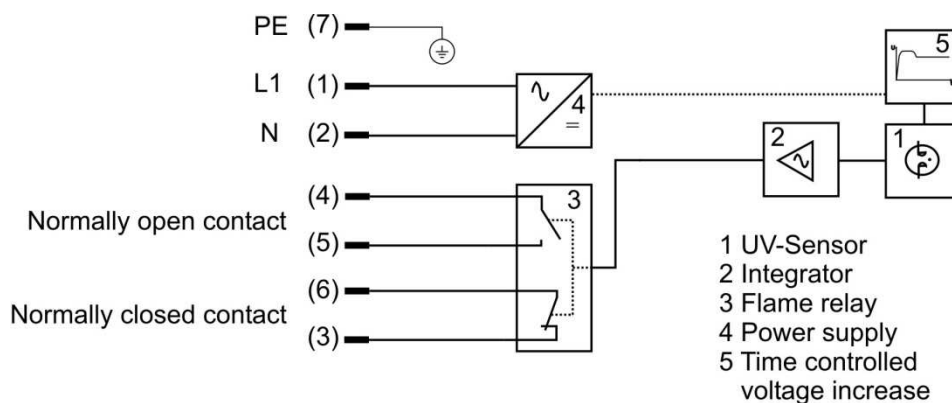

## 4 Transport, installation and connection

### **NOTICE**

*All installation and connection work may be carried out by qualified and approved specialist staff only !*

*Observe the legal stipulations and adjustment instructions of the plant operator !*

### 4.1 Scope of delivery

- Compact flame detector IFC 50
- Operating instructions (optional, customer dependend)
- Connection cable in other length (optional)

Refer to the order papers for the exact scope of delivery and compare with the delivery note.

Checking for completeness

Check the entire delivery for completeness against the accompanying delivery note. Please refer to our terms of sale and delivery otherwise.

Report any damage

After arrival of the device and accessories, notify the shipping agent, the insurance company and BST Solutions immediately in case of any damage caused by transport or inadequate packaging.

Take steps to minimise and prevent further damage.

Report the insurance case to the insurance company without delay and transmit the full claim documents at once in order to expedite the claims settlement (at the latest in sufficient time before the expiry of any periods of preclusion and/or limitation relating to the compensation claims against third parties).



## 4.2 Dimensions IFC 50

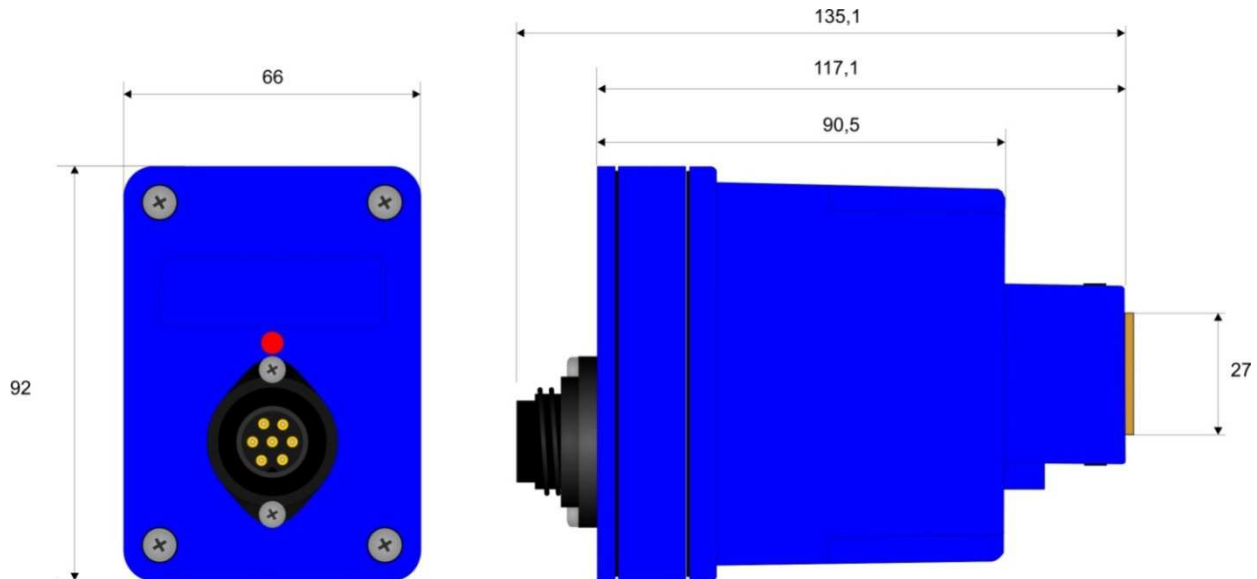

All dimensions in mm

## 4.3 Installation

### NOTICE

*All installation and connection work may be carried out by qualified and approved specialist staff only ! The legal regulations as well as adjustment instructions of the plant operator have to be observed !*

*The IFC 50 should be mounted close to the flame with straight alignment. The compact flame detector should be mounted with the diopter. The diopter guarantees a quick mounting and demounting of the compact flame controller. A diameter of 1" is recommended for viewing tube that is cut down on the port side of the rear sight to ½". The sight pipe must be adequately dimensioned.*

The alignment is to concentrate on the primary zone of the flame (flame root). The distance from the flame should be less than 2 m. Upon completion of the assembly work the screws of the rear sight to the flame menwächters are to be tightened down. At high temperature on the sight glass, which could heat the UV tube to about 60 ° C, an air connection is to be provided. To avoid interference, the direct view is to avoid a spark.

The maximum cable length of the cable is to be noted (see "Technical data). The connecting cable is to run separately from the high-energy ignition and power lines over long distances and not parallel to transfer it to.

### ⚠ DANGER

For safety reasons and technical regulations a controlled burner shut down of at least once per 24 hours must be guaranteed. Check according to EN 298:2012-11 need to check the UV tube to be used in the burner control to the controlled shutdown on the presence of a flame signal back.

**4.3.1 Alignment of IFC 50**

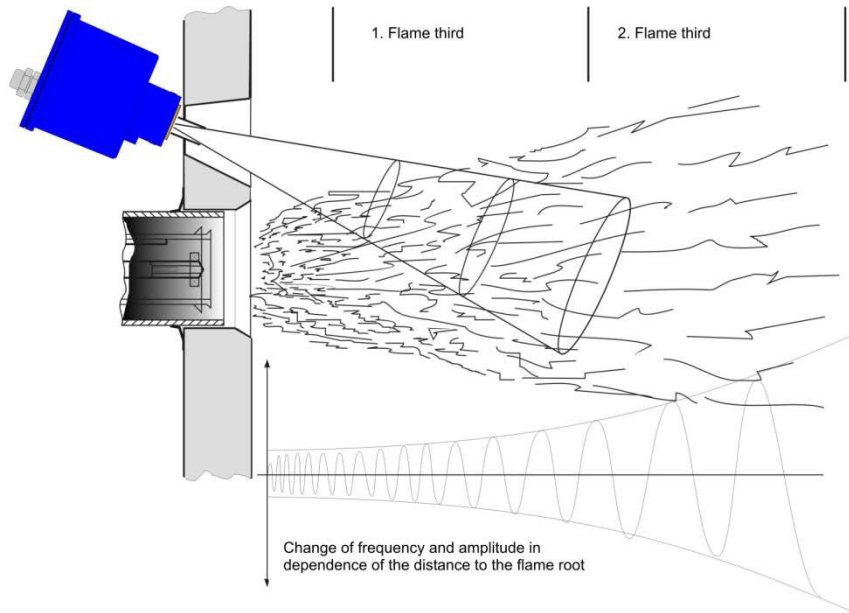

**4.3.2 Usage of glasses and lenses**

Depending on the distance and view angle to the flame, the diopter lens to be used when needed. If pressure prevailing in the combustion chamber, a diopter with quartz glass is recommended.

**4.3.3 Purge air connection**

*If the sensor temperature may rise due to high combustion chamber temperatures above 60 ° C, a purge air connection in order to limit the temperature sensor to provide a maximum of 60 ° C is essential. The dimensioning of the scavenging air is dependent on the parameters of the furnace back pressure, and the pending purge air pressure and temperatures. Purge air connections are available as the diameters ¼" and ½" optionally. The air connection is combined with the diopter. Depending on the application again lenses and glasses are available. This eliminates the normal diopter.*

**4.4 Connection**

**4.4.1 Electrical connection**

**⚠ DANGER**

*Danger to life caused by electrical current !*

*The safety instructions and local safety regulations have to be observed during connection !*

For connection data, please refer to the chapter titled "Technical data" as well as to the following terminal diagram.

Ensure that the available supply voltage complies with the voltage indicated on the type plate.

Prior to connection, check the device and the connecting cables for visible damage.

**4.4.2 Connection diagram IFC 50**

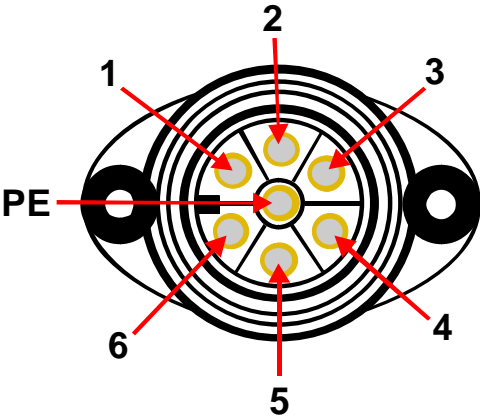
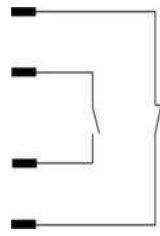
Occupancy male and female plug	PIN	Internal connection AC/DC	Connection
	1	<b>L</b>	<b>L</b>
	2	<b>N</b>	<b>N</b>
	3		<b>NC</b>
	4		<b>NO</b>
	5		<b>NO</b>
	6		<b>NC</b>
	PE	<b>PE</b>	<b>PE</b>

### 4.4.3 Connection to BMS

		Control unit	
Cable color	general	Dungs MPA 22 - connection number	More BMS on demand
grey	neutral	12 – 5 N	
black	signal	12 – 3 Ion	
brown	phase	6 – 17 L1	
green-yellow	protected earth	protected earth	

## 4.5 Storage

Do not unpack any packed compact flame detector IFC 50 and accessories.

The following conditions apply to storage:

- Store in a dry place. Maximum relative humidity 95 %. Non condensing.  
 In addition, it has to be assured that the floor in the storage area will remain dry throughout the storage period.
- Protect from direct sunlight. Storage temperature:  
 -20 degrees to +50 degrees C (-4 degrees to 120 degrees F).
- Store in a dustfree location.
- Avoid mechanical vibrations and damage.

## 5 Description

### 5.1 Functional description IFC 50

The IFC 50 is a compact UV flame detector, which is specially designed for severe conditions often experienced in industrial applications for single flame combustion. The IFC 50 can be connected directly to the ionisation or LDR input of the control box. The UV sensor ensures that the flame detector does not react to background radiation from hot refractory or from any other infrared light source.

The Flame detector has to be disconnected started up once in a day. For safety reasons and technical regulations a controlled burner shut down at least once per 24 hours must be guaranteed.

The flame detector IFC 50 has been developed to meet the requirements of UL 372-2, CSA C22.2 and EN 298. The internal 15 % increase of the UV tube voltage during the start-up phase ensures the safety requirement for the examination of the UV tube to through-ignition. The flame detector IFC 50 has to be switched off for more than 5 seconds before burner operation can be started again.

With the Dioptric holder, which serves also as a connection interface of the flame detector to the combustion chamber, the IFC 50 can be fitted with different glasses and lenses to special requirements. The flame detector is equipped with an optical interface which visibly indicates the flame signal intensity. A simple diagnosis of the flame intensity is directly on the furnace boiler possible.

## 6 Operation of the flame detector

### 6.1 Test of the flame detector

To ensure the proper operation, the flame detector has to be tested several times by starting and stopping the burner. As long as there is no flame in all cases the flame relays has to be switched off solid. The test should be repeated for different operation situations ( see also data-sheet ). This is an essential condition for a safe and proper operation.

### 6.2 Operating indicator LED

Via the built-in LED the flame detector is indicating the following operating conditions:

LED	Meaning
off	IFC 50 is without connection or there is no detected flame
Blinking	Flame is detected The blinking of the LED represents the flame signal intensity Increasing blinking = higher intensity
on	The flame is detected with highest intensity

## **7 Maintenance and servicing**

### **7.1 Cleaning**

For cleaning, use a moist cloth to wipe the housing from the outside only. For maintenance of the sight glass, please use a clean and lint free cloth. Do not use any kind of cleaning sprays or liquids.

#### **NOTICE**

*Do not scratch the glass !*

### **7.2 Maintenance interval**

There is a maintenance interval of less than 10000 hours of operation are observed. If the flame detector operated at temperatures  $> 50^{\circ} \text{C}$ , the maintenance interval is shortened considerably.

### **7.3 Safety check**

A safety check of flame monitoring must be carried out during every commissioning and maintenance of the furnace because the UV tube subjects a natural aging and the end of its life causes problems. Here the following steps should be checked:

- The attempt to start the burner flame detector is darken -> after the end of the safety time into lock indicate a fault!
- The attempt to start the burner's flame detector with an external UV radiation, eg lighter or gas flame (ambient lighting is not sufficient) to illuminate - must go into lock during the pre-ventilation mode!
- The operation of the burner flame detector is darken -> depending on type of control boxrunng must either by executing a restart attempt at the end of the safety time or immediately after darkening the burner indicate a fault!

### **7.4 Behavior in case of malfunction**

In case of malfunctioning of the flame sensor must be replaced, and send back to the manufacturer for check. Precaution after crossing the tube service life of 10,000 h should the UV tube be replaced by the manufacturer or by authorized personnel. IFC 50 is a safety component and may not be opened!

## 8 Troubleshooting

Error description	Cause	Remedy
No flame signal	I)connecting error or no active power  II) Glass dirty  III) IFC 50 malfunction IV)Tube faulty	Please check the plugs an the conne- tions of the burner controller box  Power off the IFC and take it out of the flange. Now clean the glass carefully with a clean and fuzz-free cloth  Exchange IFC Exchange tube
Ambient light interference	I) Tube faulty II) View to sparks	Exchange tube  Change view



## 9 Order data

The compact flame detector IFC 50 is available from BST Solutions GmbH under the following order data:

Item	Version	Order No.:
Flame detector <b>IFC 50 / 230</b> plug version	230 V AC	611185031000
Flame detector <b>IFC 50 / 120</b> plug version	120 V AC	611285031000

## 10 Accessories

Following accessories are offered by BST Solutions :

Artikel	Ausführung	Artikelnummer
UV-tube kit for IFC		5010-0050-12
Dioptr 1/2" with nut and gasket		114030110000
Dioptr 1/2" with UV-quartz glass plate, nut and gasket		114030112000
Dioptr 1/2" with UV-quartz glass lense, nut and gasket		114030122000
Dioptr 1" with purge air connector 1/2", nut and gasket		46530100010
Dioptr 1" with purge air connector 1/2", UV-quartz glass plate, nut and gasket		46530112010
Dioptr 1" with purge air connector 1/2", UV-quartz glass lense, nut and gasket		46530122010
Dioptr 1" with purge air connector 1/4", nut and gasket		46530100020
Dioptr 1" with purge air connector 1/4", UV-quartz glass plate, nut and gasket		46530112020
Dioptr 1" with purge air connector 1/4", UV-quartz glass lense, nut and gasket		46530122020
Connection cable with female irght-angled plug, length 1.8 m		561313041800
Connection cable with female right-angled plug,		561313043000



---

length 3.0 m		
female right-angled plug		165303041000

